



WARNING

Without a properly working safety reversing sensor, persons (particularly children) could be killed by a closing garage door. Read and follow all instructions.

To protect small children, install the safety reversing sensor so that the beam will be no higher than 4"-6" above the garage floor.

Disconnect power to the garage door opener before installing the safety reversing sensor.

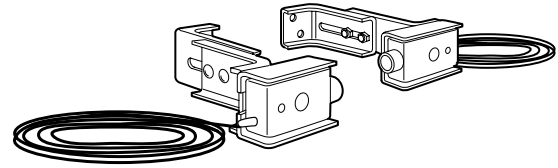

Installation procedures are the same for sectional and one-piece doors.

Be sure power to the opener is disconnected.

The sending eye transmits an invisible light beam to the receiving eye. The units can be installed on either side of the garage door as long as the sun never shines directly into the receiving eye lens.

Look at the label on the connector end of each case to identify the sensors.

The brackets must be connected and fastened so that the sending and receiving eyes face each other as shown in Figure 1.

If an obstruction breaks the light beam while the garage door is closing, the door will stop and reverse to full open position, and the opener lights will flash for 5 seconds.

The brackets *must* be securely fastened to a solid surface such as the studs on either side of the door, or add a piece of wood at each location if installing in masonry construction.

The invisible light beam path must be unobstructed. No part of the garage door (or door tracks, springs, hinges, rollers or other hardware) can interrupt the beam while the door is closing. If it does, use a piece of wood to build out each sensor mounting location to the minimum depth required for light beam clearance.

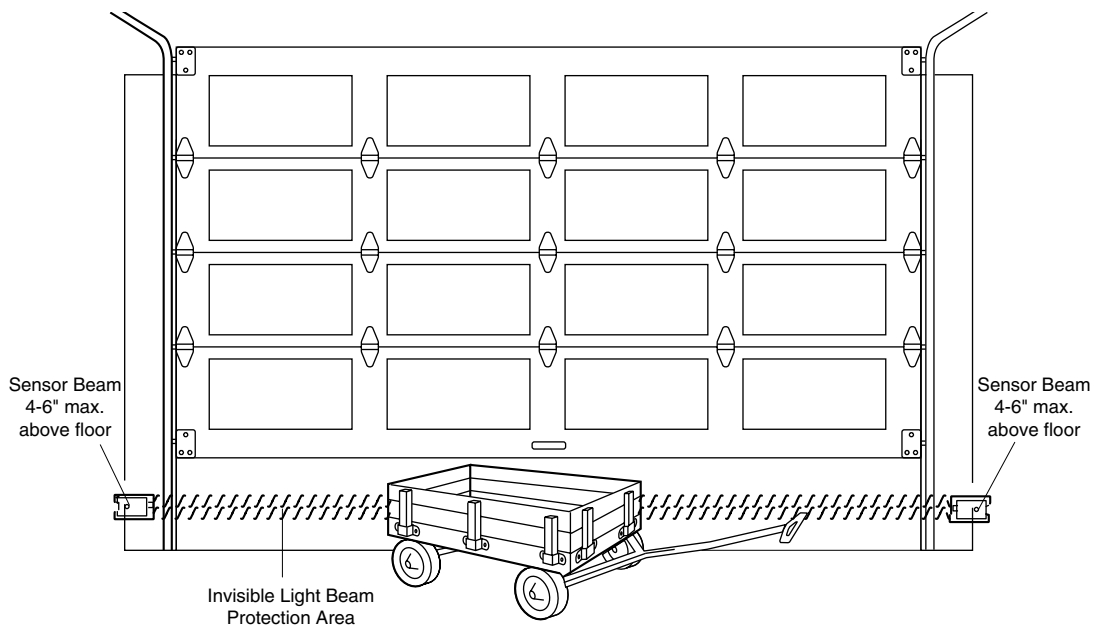

FIGURE 1 Facing the door from inside the garage

Figures 2 and 3 show assembly of brackets and "C" wrap based on the recommended installation of the sensors as shown on page 1. Figures 4 and 5 are variations which may fit your installation requirements better. **Make sure the wraps and brackets are aligned so the sensors will face each other across the garage door.**

- Fasten the "C" wraps to the mounting brackets having square holes, using the hardware shown in Figure 2.
- Connect each assembly to a slotted bracket, using the hardware shown in Figure 3.

Note the alignment of the brackets for left and right sides of the door.

- Finger tighten the lock nuts.
- Use bracket mounting holes as a template to locate and drill (2) 3/16" diameter pilot holes on both sides of the garage door, 4"-6" above the floor *but not exceeding 6"*. See Warning on page 1.
- Attach bracket assemblies with 1/4"x1-1/2" lag screws as shown in Figure 3.
- Adjust right and left side bracket assemblies to the same distance out from the mounting surface. Make sure all door hardware obstructions are cleared. Tighten the nuts securely.

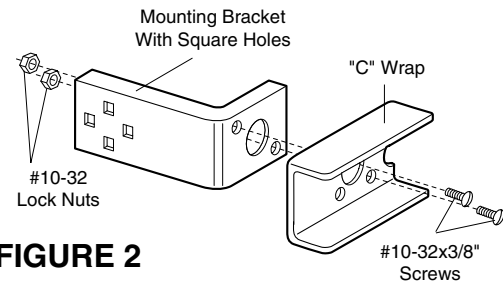

FIGURE 2

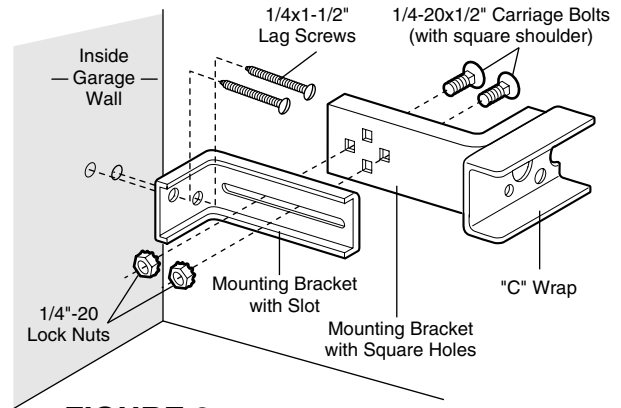

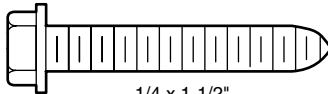

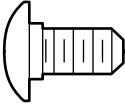



FIGURE 3

Hardware Shown Actual Size

					
#10 - 32 x 3/8" Screw	#10 x 32 Lock Nut	1/4 x 1-1/2" Lag Screw	Staples	1/4" - 20 x 1/2" Carriage Bolts	1/4" - 20 Lock Nut

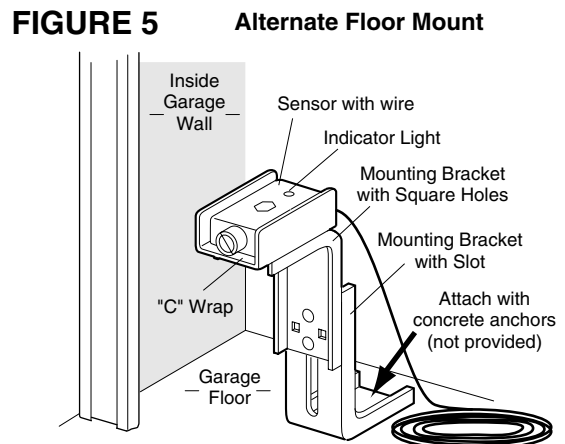
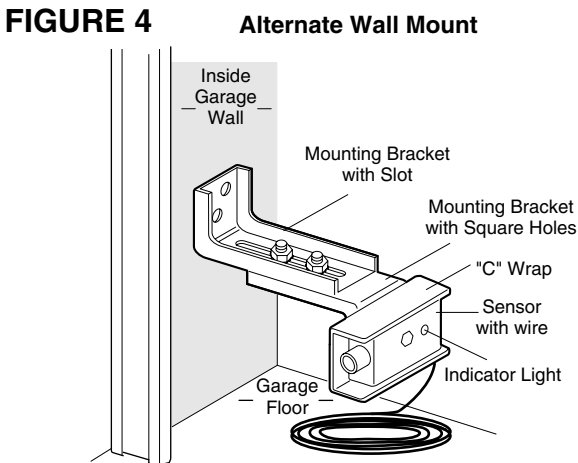
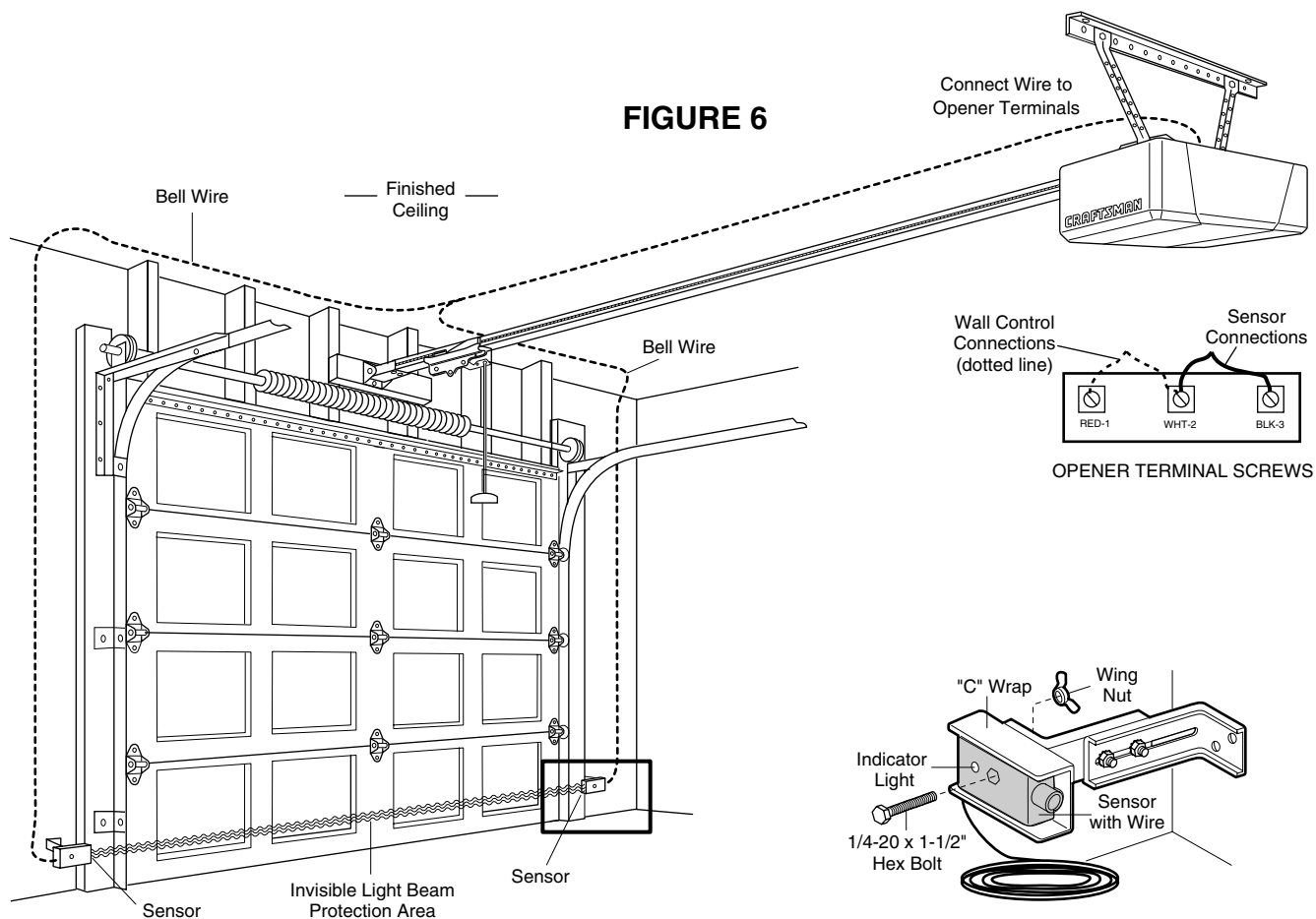

FIGURE 6



- Center each sensor unit in a "C" wrap with lenses pointing toward each other across the door.
- Secure sensors with the hardware shown in Figure 6. Finger tighten the wing nut on the *receiving eye* to allow for final adjustment. Securely tighten the *sending eye* wing nut.
- Run wires from both sensors to the opener as shown. Use insulated staples to secure the wire to the wall and ceiling.
- Connect both sets of wires to the opener terminals as shown (depending upon your model).
- Plug in the opener. If your opener has the Deluxe Wall Control, make sure the Lock Feature is *off*. Indicator lights in both the sending and receiving eyes will *glow steadily* if wiring connections and alignment are correct.

If the indicator light is *off* in the *receiving eye* (and the invisible light beam path is not obstructed), alignment is required.

- Loosen the receiving eye wing nut to allow slight rotation of unit. Adjust sensor vertically and/or horizontally until the indicator light *glows with a steady light*.
- When indicator lights are *glowing steadily* in both units, tighten the wing nut in the receiving eye unit.

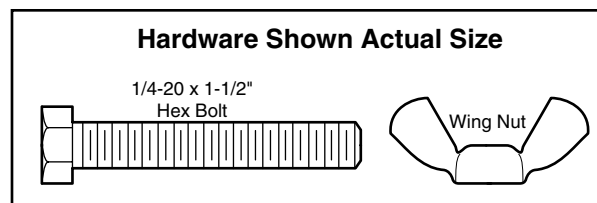

Test the Safety Reversing Sensor

- Press the remote push button to open the door.
- Place the opener carton in the path of the door.
- Press the remote push button to close the door. *The door will not move more than an inch, and the opener light(s) will flash.*

The garage door opener will not close from a remote control if the indicator light in either sensor is *off*, alerting you to the fact that the sensor is misaligned or obstructed.

The garage door can be closed by pressing and holding the Wall Control push button until down travel is completed.

**WARNING**

Without a properly working Safety Reversing Sensor, persons (particularly children) could be seriously injured or killed by a closing garage door. Repeat this test once a month.

Professional service is required if the opener closes the door when the safety reversing sensor is obstructed.

Test the Safety Reverse System

TEST:

- Place a one-inch board (or a 2x4 laid flat) on the floor, centered under the garage door.
- Operate the door in the down direction. The door **must** reverse on striking the obstruction.

ADJUSTMENT:

If the door *stops* on the obstruction, it is not traveling far enough in the down direction.

- Increase the DOWN limit by turning the DOWN limit adjustment screw counterclockwise 1/4 turn.
- Repeat the test.

On a sectional door, make sure limit adjustments do not force the door arm beyond a straight up and down position.

- When the door reverses on the one-inch object, remove the obstruction and run the opener through 3 or 4 complete travel cycles to test adjustment.

If the door will not reverse after repeated adjustment attempts, call Sears Service Center for garage door service.

**WARNING**

Failure to test and adjust the safety reverse system may result in serious injury or death from a closing garage door. Repeat this test once a month and adjust as needed.

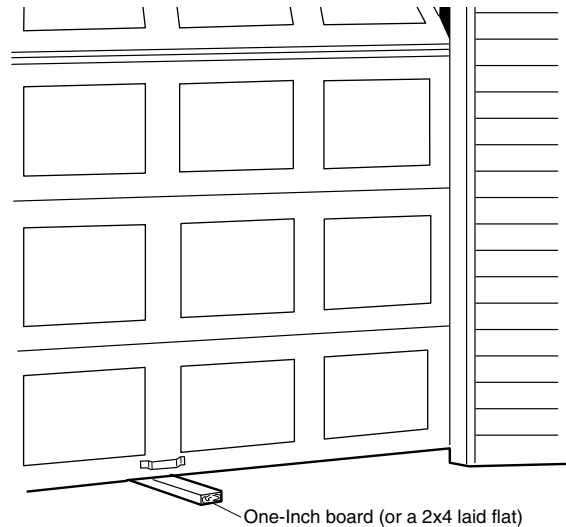

Trouble Shooting

1. If the *sending eye* indicator light does not glow steadily after installation, check for:
 - Electric power to the opener.
 - A short in the white or black/white wires. These can occur under staples or at screw terminal connections.
 - Incorrect wiring between sensors and opener.
 - An open wire (wire break).
2. If the *sending eye* indicator light glows steadily but the receiving eye indicator light doesn't:
 - Check alignment.
 - Check for an open wire to the receiving eye.

Replacement Parts

Safety Sensor Kit (receiving and sending eyes with 3' 2-conductor bell wire attached)41A4373A	C-Wrap Bracket12B483
Safety sensor hardware bag41A4116	Square Hole Bracket12B484
	Slotted Bracket12B485